

**PRINCIPLES
OF
SOIL
SAMPLING**

FOR NORTHWEST AGRICULTURE

PRINCIPLES OF SOIL SAMPLING FOR NORTHWEST AGRICULTURE

Thousands of soil samples are tested each year in the Northwest to predict fertilizer needs and diagnose crop growth problems. The value of soil testing has been well established. Twenty-five years of soil fertility and soil test correlation research in the Northwest have resulted in soil test adequacy levels in which, in general, we can have considerable confidence.

This publication is an outgrowth of an attempt by the Northwest Soil and Plant Testing Work Group to coordinate and standardize soil sampling procedures for Washington, Oregon, Idaho, Utah, and Montana. Because of the wide variety of crops, soils, climate, management, and nutrient requirements in the Northwest, it is difficult to outline soil sampling methods for the region.

To the extent possible, standard sampling procedures should be established on a regional basis. A given sampling procedure based on a given set of field conditions should not be limited by state boundaries. For example, sampling methods for irrigated potatoes should be somewhat similar, regardless of location, within the Northwest States. The same is true for other crops and management systems common to different areas of the Northwest.

This publication attempts to establish basic principles for soil sampling for most situations in the Northwest. Detailed procedures may be found in literature published by each state Extension organization. Sampling procedures for special situations, which are not generally available, will be described. Relevant literature references are listed.

The Soil Variability Problem

Soils are variable. In fact, most surface soils vary a great deal within short distances across the landscape. Soil variability is apparent as one sees the differences due to topography, cropping, soil depth, drainage, moisture, etc. What is not readily apparent is the variability that cannot be seen and can be detected only by testing soil samples taken at intervals across a field. This is well illustrated in Figure 1, which shows soil test levels for P at 50-foot intervals on a grid in a field which appeared to be uniform. The field was heavily

leveled in preparation for rill irrigation, which explains the extreme variability. However, research has shown that undisturbed fields that appear to be uniform are usually variable in soil test levels.

In general, instructions are available for sampling where variability can be seen, but not for the numerous situations of unseen variability.

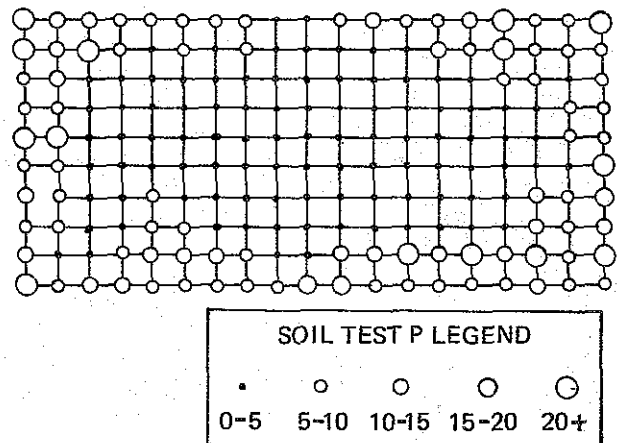

Figure 1. Variability in soil test P in a 12-acre field.

Some Basic Guidelines

Establishing Sampling Units

Separate areas of dissimilar soil type or soil condition. Do not include different soil types or different soil conditions, such as well drained versus poorly drained, in the same composite

DEFINITIONS

Composite Soil Sample—A sample composed of a number of individual soil cores which are thoroughly mixed.

Point Sample—A sample consisting of five cores collected within a radius of 6 feet. It is really a composite sample taken from a very small area.

Sampling Unit—An apparently uniform area to be sampled for diagnosis or for predicting fertilizer needs. It may be a field or a part of a field. The sampling unit may be sampled via one composite sample or via a number of point samples.

sample. These different soils will often have different fertilizer requirements which would not be apparent if they were mixed together.

Separate areas of dissimilar past management. Past soil management, such as crop grown or fertilizer application, is likely to affect the fertilizer requirements of the soil. Take separate samples from areas of different past management programs.

Avoid unusual areas. Sometimes there are small areas caused by such things as spilled fertilizer, dead furrows, animal droppings, or burned slash or straw piles. Subsamples from such areas can seriously affect the composite sample. If unusual areas in a field are large enough to be sampled, do it separately from the rest of the field.

Consider unseen variability. A sampling unit that appears to be uniform will generally have considerable variability in soil test values. Thus, one composite sample from a sampling unit may be very misleading. Consider intensive sampling procedures (see page 4).

Use Good Equipment

The recommended and most frequently used tool is the open-face, 36-inch soil sampling tube graduated to either 6 or 12 inches. The inside diameter is usually $\frac{3}{4}$ inch and the open-face slot is usually approximately 12 inches long (see Fig. 2).

If a sampling tube is not available, one can use an irrigation shovel in an attempt to simulate the sampling done by a tube, but, at best, the sampling job will not be as good. If sampling is difficult because of gravel, hardpan, etc., one may have to use a soil auger. For sampling below 3 feet, the Veihmeyer tube¹ is best. In some cases, such as in large fields or sampling units, a pickup-mounted hydraulic sampler is useful.

Sampling equipment should be clean and constructed of stainless steel. Descriptions of various types of sampling tools and instructions for their use are available from Extension organizations.

Maintain Sample Integrity

Avoid contamination. Soil samples can become contaminated through the use of dirty sampling tools such as soil probes, spades, and mix-

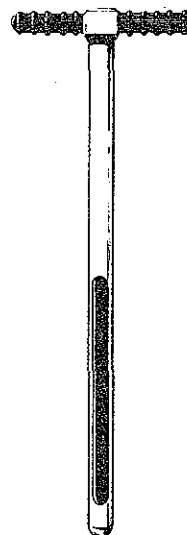

Figure 2. An open-face sampling tube, the tool most commonly used for most situations. The tip is slightly enlarged on the outside and slightly tapered inward on the inside for efficient sample extraction.

AVOID CONTAMINATING THE SAMPLE

- * Use clean sampling tools and utensils.
- * Mix the sample with clean hands and use clean, nonabsorbent packaging materials.
- * A small amount of fertilizer residue on tools or hands can seriously contaminate a soil sample.

ing buckets. Contamination from fertilizer material is particularly serious, thus keep soil sampling equipment and soil samples away from fertilizers. Also, make sure the hands and clothing of people taking soil samples are not contaminated with fertilizer or chemicals. Stainless steel or aluminum alloy sampling tools and plastic buckets are essential, especially when the sample is to be tested for micronutrients.

For the $\text{NO}_3\text{-N}$ test, stop biological activity by air drying or freezing samples the same day they are taken. Use plastic-lined, coated, or other containers that will not absorb moisture. Avoid the use of porous paper bags.

Sampling Procedures

Sampling procedures to be used depend, to a great extent, on whether the nutrients involved

¹ A Veihmeyer tube, commonly known as the King tube, is a heavy enclosed steel tube with a detachable point. It requires pounding with a heavy, specially made hammer. It can be obtained from Hansen Machine Works, -728-12th Street, Sacramento, CA 95814.

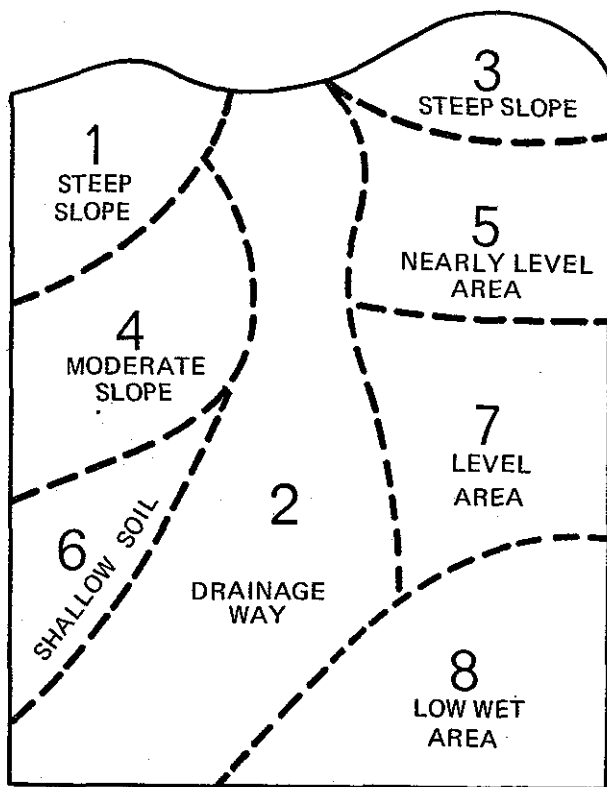

Figure 3. Diagram of a field or fields to be sampled. Each numbered area is a "sampling unit," which may vary from less than 1 acre to many acres.

are mobile in the soil. Nonmobile nutrients that have been broadcast and incorporated remain more or less throughout the upper 8 to 10 inches of soil. Mobile nutrients move downward under sprinkler irrigation or downward and sidewise under rill irrigation, ending up in wide bands near the surface.

Nonmobile Nutrients

Nutrients that are regarded as nonmobile include P, K, Ca, Mg, Fe, Mn, Zn, B², and Cu. Tests may also include pH, organic matter, lime requirement, or gypsum requirement. (Most states have a standard or regular test that may include P, K, pH, organic matter, and sometimes Ca and Mg.)

Sample Depth—Surface Soil. In general, the recommended sample depth for predicting fertilizer needs for nonmobile nutrients in tilled, irrigated soils is 0-12 inches. In certain situations, it may be desirable to split the surface foot into two samples. For example, in nontilled pastures of western Oregon, it has been found that there is an advantage to taking samples 0-2 and 2-12

inches. For nonirrigated soils, the sample depth is the depth of tillage.

Sample Depth—Subsoil. Although recommendations for nonmobile nutrients are generally based on the surface sample only, taking an occasional subsoil sample should be encouraged and may provide additional information. For example, subsoil high in P may receive a recommendation for a reduced rate of P.

Sampling Intensity. The goal of every farm operator should be uniformly high production, through uniformly high, but not excessive, soil fertility. This can be accomplished only by judicious use of fertilizer based on an adequate soil sampling-soil testing program.

Sampling should be sufficiently intensive to identify the variability patterns in a field. Economics will govern the degree of sampling intensity to a considerable degree. Intensive sampling is especially applicable for high value crops such as potatoes. It is especially important to determine and reduce variability before planting long-term, high-value crops such as grapes or tree fruits.

Visible or Known Variability (Fig. 3)—Sample separately areas that are different from each other because of slope, soil depth, texture, wetness, leveling, previous crop, etc. Each soil condition should be represented by at least one sample. Adequate instructions for the usual situations, including diagrams, are provided by Extension organizations in the Northwest.

Unseen Variability (Fig. 1 and 4)—Unseen variability can be measured by sampling intensively on a grid system. The optimum intensity of sampling will depend on the intensity of agriculture and the degree of suspected variability. For example, in leveled, irrigated soils used for growing high value crops, one may increase the intensity from one composite sample from a 20-acre field to point samples on a 200-foot grid. On the other hand, in an apparently uniform quarter section of dryland wheat, in the area of less than 12 inches of rainfall, one should increase the intensity of sampling from 1 composite sample for the 160 acres to 4 to 8 or even 16 point samples uniformly distributed across the

² B is mobile, but somewhat less mobile than N or S. In some cases, depth samples should be taken, as in diagnosing possible B deficiency or toxicity problems in deep-rooted perennials (see page 5).

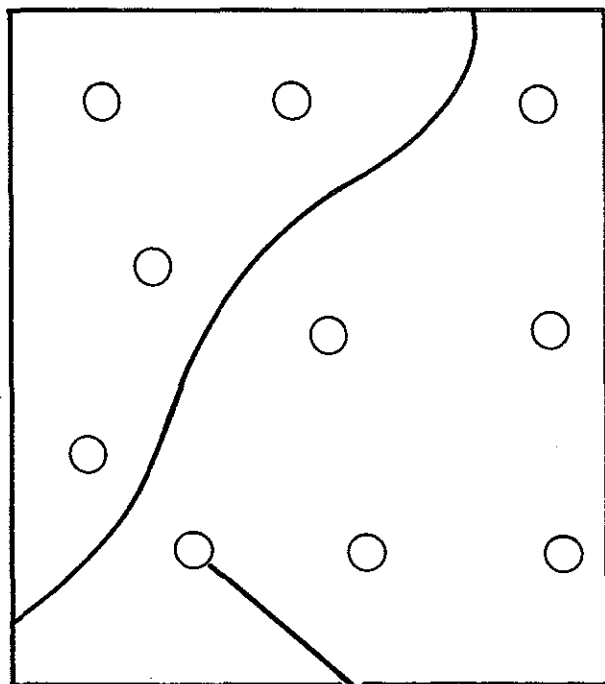

Figure 4. Intensive sampling of a 10-acre field containing two sampling units. Each circle, approximately 10 feet in diameter, represents a "point sample." Each X represents one sample core taken with a soil tube. Each point sample is kept separate from all others.

area. (An area within a 20-foot radius can be considered a point sample when sampling dry-land wheat.)

In areas where there are considerable topographic variations, soil fertility units can be delineated into sampling units as follows: (a) hill-tops and ridges which generally have moderate to severe erosion, (b) broad sloping areas, (c) bottom land. However, within each of these areas there may be some variation. To gain an estimate of this "unseen" variation, take a minimum of three point samples at equidistant points within the sampling area.

In any case, the practice of collecting composite samples from large "uniform" areas should be replaced with somewhat more intensive sampling. Figure 5 is an example of differential fertilization based on intensive sampling.

Monitoring Sites. After the initial fertilizer program based on intensive sampling is completed and/or the operator is satisfied that a reasonable degree of uniformity exists, soil test levels in fields or areas can be monitored with much less

intensive sampling than initially. Monitoring will especially lend itself to large farms, but can also be used for smaller operations.

Soil test monitoring refers to periodic measurement of soil test changes with time in a field or area within a field. A relatively small area within the field—a monitoring site—is permanently established for this special purpose. The size of the monitoring site may vary from 1 to 5 acres, depending on the size of the area to be represented. Each year a composite sample from a monitoring site will be used as a basis for an adjustment in the soil fertility program of the entire field. It would also be desirable to include plant analysis along with the soil tests. Monitoring sites provide a reference point that can be compared with areas having nutritional problems that become apparent during the season.

120 LB/A			80 LB/A			
2.8	3.3	2.4	4.8	4.8	6.3	
2.8	2.8	5.2	5.8	4.8	3.3	120
2.0	4.8	4.2	6.3	1.6	2.4	LB/A
6.3	6.8	23.2	4.2	3.3	12.0	
8.3	12.7	5.2	20.7	10.6	9.9	
11.2	9.9	13.4	9.3	12.0	15.0	
6.8	19.7	8.6	23.2	9.9	9.3	
			30 LB/A			

Figure 5. Soil test values for P on a 100-foot grid and recommended rates of P_2O_5 for the different areas. This is an example of variability within a 10-acre sampling unit that appeared to be uniform. It is especially important to determine and reduce variability before planting long-term and/or high-value crops.

Mobile Nutrients

Sampling problems for nutrients that are mobile in the soil—N, S, and B^3 —are quite different from problems for immobile nutrients:

1. Applied mobile nutrients move more or less freely with the movement of water in the soil. This means it is necessary to sample through-

³ N and S are somewhat more mobile than B. For routine testing for B sampling, only the surface foot or two feet may be adequate.

out a major part of the rooting depth of the crop to be planted.

2. Variability patterns are usually different from those of immobile nutrients. Variability of N, S, and B relate more nearly to previous applications of these nutrients and to the movement of water rather than to levels of indigenous elements, as is the case with P and K, for example. Also, depth patterns of mobile nutrients will frequently be different between the "head" ends and "tail" ends of irrigation runs under rill irrigation.

Depth. Take samples by foot-depth increments to the rooting depth of the crop or to the depth of soil, whichever is less. For example, for sugar beets, it may be important to know the amount of available N in the top foot for the young sugarbeet seedlings. Also, it may be important to know the N level in the bottom foot, which may reduce sugar concentration due to availability late in the growing season. Depth for corn, small grain⁴, asparagus, hops, grapes, tree fruits, and sugar beets is 5 feet. For beans, potatoes, peas, onions, and mint it is 3 feet.

In some instances, research has shown the validity of sampling to shallower depths than those shown. Examples are:

- (1) N for sugar beets—3 feet,
- (2) S for alfalfa—2 feet, and
- (3) B for alfalfa and sugar beets—1 foot.

However, it must be remembered that high levels of the nutrient in question found below the depth of sampling may invalidate the tests for that nutrient.

Intensity and Sampling Pattern. Take at least 15 cores from each sample area for the surface foot, 10 cores for the second, and 5 for each depth below 2 feet.

Under sprinkler irrigation, take the samples at random throughout the sampling area. Under rill irrigation, special sampling procedures are

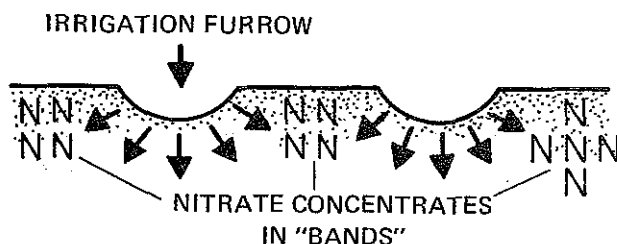

Figure 6. Movement of soil, water, and nitrate-N with relation to the irrigation furrow.

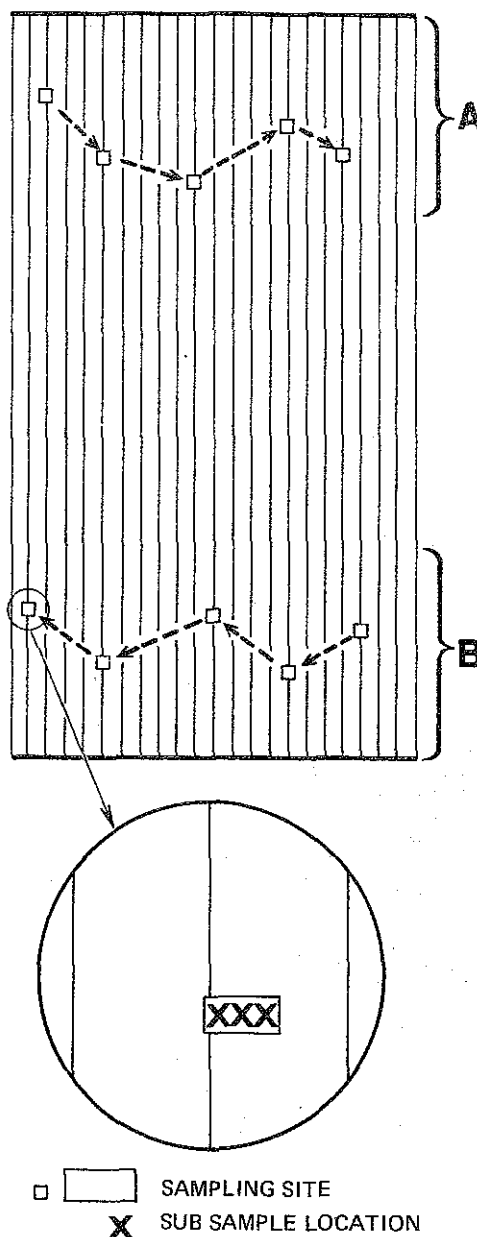

Figure 7. Sampling pattern for a rill-irrigated field.

necessary because of the banding effect on mobile nutrients of irrigation water moving laterally from the rills.

Also, under rill irrigation, keep samples from the "head" and "tail" end of runs separate because they are likely to be different. Special sampling instructions for sampling for $\text{NO}_3\text{-N}$ are available. See Figures 6 and 7.

⁴For dryland wheat, where moisture is also to be determined, take samples to 6 feet or to the depth of soil, whichever is less.

Saline and Sodic Soils

Depth. Suggested minimum depth sampling is as follows:

- (1) tillage depth,
- (2) bottom tillage depth to 18 inches, and
- (3) 18 to 36 inches.

If the tillage or plow depth is 10 to 12 inches, it may be desirable to sample both 0 to 6 and 6 to 12 inches, especially if the crop to be planted has shallow roots. Also, there may be some advantage in taking additional samples below 36 inches, especially in the worst areas.

Intensity and Sampling Pattern. The best time to sample is when a crop (or weeds) is growing in the field. Thus, the affected areas can be seen and sampled accordingly. Take samples 1) within the affected area, 2) outside the affected area (presumably this situation will be more nearly normal), and 3) borderline situations between "good" and "bad" areas. Keep these samples separate from each other.

Special Problems

Special problems include a variety of situations where diagnosis of nutrient deficiency or toxicity is attempted. Many of these are localized, individual situations which do not lend themselves to standardization or generalization, but require on-the-spot judgment. However, guidelines used by workers in some states may be of benefit to workers in others where somewhat similar problems are encountered.

Suspected High Salt from Rill Irrigation. Salts from fertilizer or from other sources move horizontally with the water out from the irrigation rill and concentrate within the crop row (Fig. 6). Probably the crop most commonly affected is mint, but the problem occurs in other row crops.

For diagnosis, the salt level must be determined on samples taken from the zone of highest root concentration. For mint, this zone is the 0 to 6-inch depth within the mint row. This is the most commonly used depth for most crops, but may vary somewhat.

Take samples at 0 to 6 inches and 6 to 12 inches in the row and 0 to 6 inches in the rill for comparison. Take composite samples within the affected area in each of the three above locations. It is also advisable to sample similarly in a normal area of the field.

Chemical Problems in Orchards. Serious problems are encountered in some orchards where acid-forming fertilizers have been applied in concentrated bands around trees for several years. The result is a marked reduction in pH, with resultant Mn toxicity. Sometimes medium to high salt levels have developed. Arsenic toxicity is also sometimes involved.

Samples are taken by foot-depth increments between the trunk and drip line. Usually the problem area to be sampled is within 3 feet of the trunk, depending on where fertilizers were applied. The depth increment samples are kept separate. If the area of fertilizer application is not known, separate samples may be taken at varying distances from the trunk to determine the locations of the problem. Samples are also taken in an area between trees for comparison.

References on Soil Sampling

General Sampling Instructions

- Christensen, Paul D. 1962. Soil Tests. Utah State University, Extension Leaflet 3.
- Gardner, E. H. 1972. How to Take a Soil Sample and Why. Oregon State University Extension Cir. 628.
- Halvorson, A. R. 1973. Taking Routine Soil Samples - for Cultivated Crops. Washington State University, Extension Cir. 387.
- Park, Frank. 1971. Soil Sampling. University of Idaho. Current Info. Series No. 162.
- Sims, James R. Soil Sample Information Sheet. Montana State University, Plant and Soil Science Department.
- Smith, Charles M. 1974. Diagnostic Methods. Chapter VII in *The Fertilizer Handbook*. National Plant Food Institute.

Sampling for Nitrate - N

- Dow, A. I. 1969. Interpretation of Soil Test Nitrogen for Irrigated Crops in Central Washington. Washington State University, EM 3076.
- Gardner, E. H. 1971. OSU Soil Test for Nitrate Nitrogen. Oregon State University, Extension Cir. 770.
- James, D. W., C. E. Nelson, and A. R. Halvorson. 1967. Soil Testing for Residual Nitrates as a Guide for Nitrogen Fertilization of Sugarbeets. Washington Agr. Exp. Sta. Cir. 480.

Soil Variability and Intensive Sampling

Dow, A. I. and D. W. James. 1973. Intensive Soil Sampling: A Principle of Soil Fertility Management in Intensive Irrigation Agriculture. Washington Agr. Exp. Sta. Bul. 781.

Dow, A. I., D. W. James, and T. S. Russell. 1973. Soil Variability in Central Washington and Sampling for Soil Fertility Tests. Washington Agr. Exp. Sta. Bul. 788.

James, D. W. and A. I. Dow. 1972. Source and Degree of Soil Variation in the Field: The Problem of Sampling for Soil Tests and Estimating Soil Fertility Status. Washington Agr. Exp. Sta. Bul. 749.

Kunkel, R., C. D. Moodie, T. S. Russell, and N. Holstead. 1971. Soil Heterogeneity and Potato Fertilizer Recommendations. Amer. Potato J. 48:163-173.

Washington Soil Improvement Committee. 1973. Intensive Soil Sampling—A New Approach to an Old Problem. Northwest Plant Food Association leaflet.

Sampling Saline and Sodic Soils

Hausenbuiller, R. L. 1957. Sampling Saline and Alkali Soils for Laboratory Analysis. Washington Agr. Exp. Sta. Cir. 303.

Sayegh, A. H., L. A. Alban, and R. G. Peterson. 1958. A Sampling Study in a Saline and Alkali Area. Soil Sci. Soc. Amer. Proc. 22:252-254.

Soil Sampling in Orchards

Dow, A. I., A. R. Halvorson, and R. B. Tukey. 1969. Instructions for Taking Soil Samples in Orchards. Washington State University, EM 3057.

This publication was prepared by The Northwest Soil and Plant Testing Work Group. It was edited by A. I. Dow, Extension Soil Scientist, Washington State University, Prosser. Members of the Work Group who contributed to the writing are E. Hugh Gardner, Oregon State University, Corvallis; T. L. Jackson, Oregon State University, Corvallis; J. Preston Jones, University of Idaho, Moscow; Charles G. Painter, University of Idaho, Twin Falls; A. R. Halvorson, Washington State University, Pullman; Reuel Lamborn, Utah State University, Logan; Neil Christensen, Montana State University, Bozeman; Glen Leggett, USDA-ARS, Kimberly, Idaho.

The authors hope that the publication will be useful to corporate farm managers, fertilizer fieldmen, management consultants, Extension agents, Extension specialists, and research personnel in soil fertility management.



A Western Regional Publication

Issued in furtherance of Cooperative Extension work, Acts of May 8 and June 30, 1914, in cooperation with the United States Department of Agriculture. J. O. Young, Director, Cooperative Extension, Washington State University. Other Extension Directors are James W. Matthews, University of Alaska; Craig S. Oliver, University of Arizona; J. B. Kendrick, Jr., University of California; Lowell H. Watts, Colorado State University; William R. Furtick, University of Hawaii; Fred E. Kohl (Acting), University of Idaho; Carl J. Hoffman, Montana State University; Dale W. Bohmont, University of Nevada; L. S. Pope, New Mexico State University; Henry A. Wadsworth, Oregon State University; Clark Ballard, Utah State University; Harold Tuma, University of Wyoming. Extension invites participation in its programs and offers them to all people without discrimination. Use of a trade name does not imply endorsement of one product over another. Published March 1979. Reprinted July 1981.